

Product weight	12.9kg
Water pressure range	0.05MPa (flow pressure)~0.20MPa (flow pressure) *Secondary side pressure (after shower faucet)

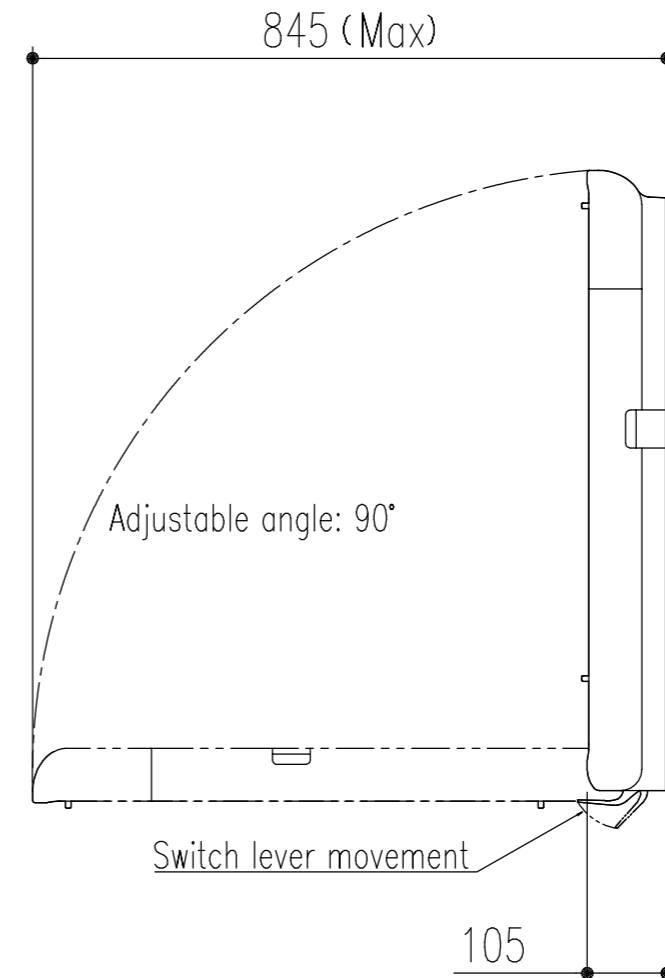
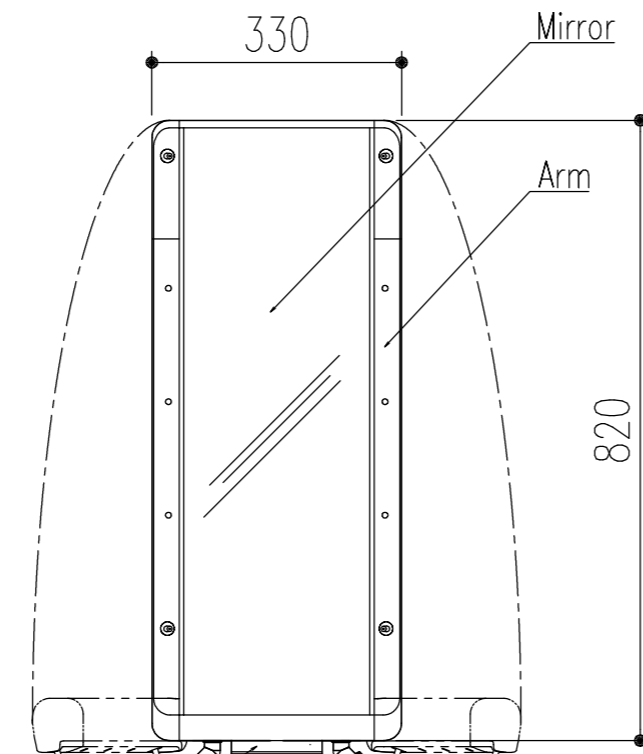

(\*PJ1/2 is compatible with G1/2)

Water outlet (PJ1/2, Male)  
(\*To handheld shower)

Switch lever

Water inlet (G1/2, Female)  
(\*From shower faucet)

Connection hose

\*Body shower and handheld shower cannot be used at the same time.

Part name	Specification Drawing Body Hug Shower	Date	2022.06.28
Part number	White: NYSA-1-R-SET(WR)/FW1 Black: NYSA-1-R-SET(WR)/N11	Scale	1/10
Drawing number	220628a	<b>株式会社 LIXIL</b>	